



SOLAR INVERTER



User Manual

Content

1、 Installation Instructions-----	1
2、 Outlook of Inverter-----	2
3、 LCD display -----	3
4、 Operation -----	6
5、 Working Modes -----	7
6、 Wiring -----	8
7、 Maintenance -----	9
8、 Error and Solution -----	9
9、 Appendix: 485 Communication Port-----	11
10、 Technical specification -----	12
11、 Maintenance Record-----	13



Warning

This is A class inverter. It might cause slightly radio interference in daily life. And practical measure is required to take under this condition.

Preface

Thank you for the purchase of on/off grid hybrid solar inverter (Hereinafter referred to as inverter). Please read this manual carefully before installing and using the inverter!

Copyright

We have been devoted to technological innovation and aims to meet the demands of its customers with better product and services. And product design and specification would be updated without prior notice. Please in kind prevail!

1.Installation Instructions

1-1: Open-package inspection

1. After opening the package, please check random accessories, including user manual(contains conformity certificate and warranty card), 2pcs battery cables and accessories for optional functions. And check whether the inverter is still kept well after transportation, if find any broken or component missing, do not turn on the machine, feedback to the carrier and distributor.

Note:

- **Please keep the packing box and packing material, can be used for next delivery if needed.**
- **This series of product is very heavy (check appendix as reference), please handle with care when carrying.**

1-2: Installation notice

The machine shall be installed by the professional and wiring shall be carried out in accordance with local electrical regulations and the following instructions. For safety, please cut off the city power distribution switch and battery input switch before installation.

- 1) Install in an area of well ventilated, free of water, burning gas and corrodent.
- 2) Not good to put on the side, better keep good air ventilation from front panel's bottom air intake, or air outlet from back panel's fan, and side face of machine.
- 3) Around environment temperature should remain -15 to 45 centigrade.
- 4) If disassembling and operate under low temperature environment, may happen water condense, only can work till thorough dry of machine inside and outside, otherwise will be shock risk.
- 5) If the machine is placed for a long time, it should be confirmed that the machine is completely dry and no corrosion can be installed and used.
- 6) Preparation of the wire: Use a cable that matches the current, choose a length you need, peel off 5mm insulation of the terminal which connects to the inverter, and then press the terminal to minimize the length of the connection to reduce the loss of cable. The system cable is selected based on the current density of no greater than 4A/mm². (External connection cables such as photovoltaics, batteries, inputs, output connection cables, etc. are not attached with the inverter. The users need to purchase separately.)

Note:

- **Please turn off the load before connecting to the inverter;**
- **Batteries and PV input need to be equipped with circuit breakers with breaking capacity;**
- **This product can only protect high voltage surge of small energy. In areas of frequent lightning incidence, it is recommended to install lightning protection device outside the PV input terminal;**
- **Please connect an over-current protective device to AC input of inverter;**
- **Please check grounding of inverter for the safe of user and the normal operation of inverter;**
- **Inverter should be chosen based on the start up power of inductive loads, likemotor, monitor and laser printer, etc. usually, it is 2 to 3 times higher than the rated capacity of inductive loads.**

1-3: Placement

Please leave 10cm of space for each side of inverter to keep good air circulation.

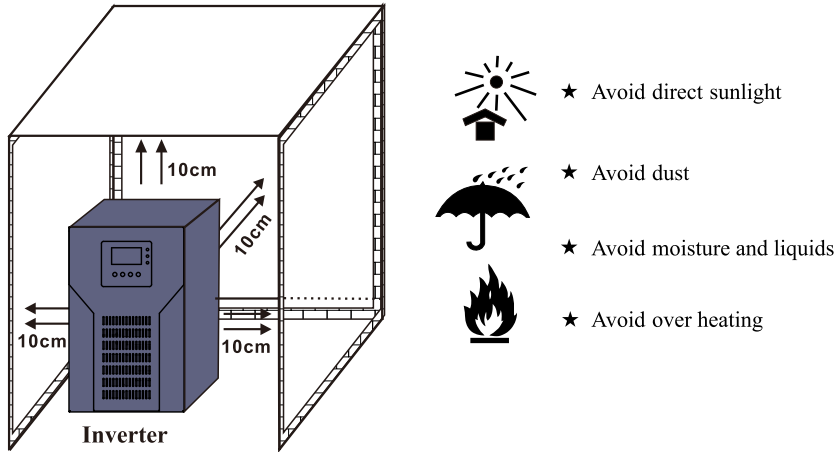

2. Outlook of Inverter

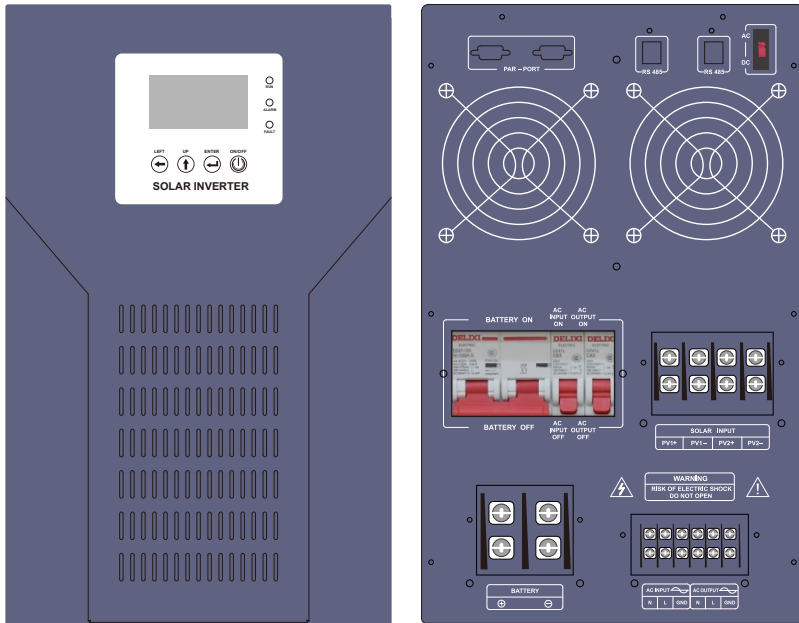

Note: Images may be slightly different from actual product. Please in kind prevail!

3: LCD Display

3-1: Display control panel layout

This series inverter display control panel is shown in figure 3-1.

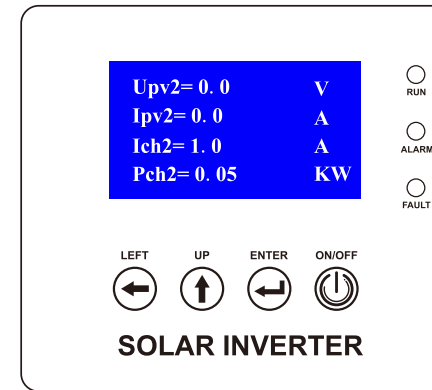

Figure 3-1

The panel of the display control area is divided into: LED display area, function key control area and LCD display area as shown as the figure 3-1.

3-2: LED Indication

The three light-emitting diodes (LED) in the LED display area as indicators of operating status and faults. .

(RUN):Run light. Flickering indicates that the system program is running normally.

(ALARM): Alarm light. When it's on indicates that there is warning information and when it's out indicates that it's normal.

(FAULT): Fault light. When it's on indicates that the inverter malfunctions and when it's out indicates that the inverter is normal.

3-3: Function key

There are 4 Function Keys shown as the figure 3-1.

(LEFT): Setting value as left shift key; press for 2 seconds to clear fault information and initialize LCD display.

(UP): Setting the interface parameters as number added key.

(ENTER): In the parameter setting interface, it is the key to determine; in other interface, it is the page turning key to check the operation information.

(ON/OFF): Switch key. Press for 2 seconds to switch on or switch off.

Compound Key

There are 4 Function Keys shown as the figure 3-1.

(LEFT) & (UP): Parameter Checking Key. Press the keys at the same time into parameter interface to check the charging voltage and current.

(UP)&(ENTER): Parameter Setting Key. Press the keys at the same time into parameter interface and input the password "103" to set the charging voltage and current.

(LEFT)&(ENTER): Menu Return Key. Press both keys at the same time to exit from parameter checking interface and parameter setting interface.

3-4: Information Display Instruction

3-4-1: Running information (Go through with ENTER key)

1) PV1 information

Upv1= -0.1	V
Ipv1= 0.0	A
Ich1= 1.0	A
Pch1= 0.05	KW

Upv1: PV1 input voltage
Ipv1: PV1 input current
Ich1: PV1 output current
Pch1: PV1 output power

2) PV2 information

Upv2= 0.0	V
Ipv2= 0.0	A
Ich2= 1.0	A
Pch2= 0.05	KW

Upv2:PV2 input voltage
Ipv2: PV2 input current
Ich2: PV2 output current
Pch2: PV2 output power

3) Battery and power generation information

Ubat=51.9	V
Ibat= -0.3	A
DAY_W=0.0	Kwh
TOT_W=53	Kwh

Ubat:Battery voltage
Ibat: Battery current(positive value means charging current; negative value means discharging current)
DAY_W: Day generation
TOT_W: Total generation

4) Temperature and PV power information

Tpv1= 23	°C
Tpv2= 24	°C
Tinv= 28	°C
Pch=0.10	KW

Tpv1:PV1 radiator temperature
Tpv2: PV2 radiator temperature
Tinv: Inverter radiator temperature
Pch: Total pv output power

5) Inverter output information

Uinv=220.0	V
ILinv=2.4	A
IHinv=0.2	A
Pinv=0.04	KVA

Uinv: Invert voltage
ILinv: Low voltage side current of inverter transformer
IHinv: Invert output current
Pinv: Invert output power

6) Load information

Uload= 220.3	V
Iload= 0.2	A
Pload= 0.04	KVA

Uload: Load voltage
Iload: Load current
Pload: Load power

7) Grid information

Ugrid= 0.2	V
Igrid= 0.3	A
Pgrid= 0.00	KVA
Freq= 0.00	Hz

Ugrid: Grid voltage
Igrid: Grid side current
Pgrid: Grid side power
Freq: Grid frequency

8) Loads and working status information

Uload=220.3	V
Iload=0.1	A
BATTERY MODE	
PV1 PV2 BAT GRID	

Uload:Load voltage
Iload: Load current
BATTERY MODE/GRID MODE:
Working modes of the inverter:
Battery mode / Grid mode
“PV1” is displayed when PV1 is working.
“PV2” is displayed when PV2 is working.
“BAT” is displayed when battery is discharging.
“GRID” is displayed when grid is working

9) Warning information

ALARM TYPE	
Ugrid Low	
10100	0 0 0 0

Warning type display

3-4-2 Parameter setting instruction

1) Input the password “103” to enter the value setting interface.

PASSWORD
PW= 000

2) Choose to save the interface or not before exiting parameter setting (Save the data based on the demand. When exiting, the machine will be shut down to save the data, and then reboot.)

SAVE OR NOT
YES NO

3) Battery constant charging voltage setting interface(Range: 12V-17V)

U_CHARGE_EQUAL
U=013.8V
0

4) Battery floating charging voltage setting interface(Range: 12V-17V)

U_CHARGE_FLOAT
U=013.7V
1

5) PV charging battery current setting (In default, MPPT charges at maximum current, and 0.1C is recommended. For example: 100AH*0.1=10A)

PV_CHARGE_I
I=0020A
2

6) Grid charging battery current setting(In default 20A, 0.1C is recommended. For example: 100AH*0.1=10A)

AC_CHARGE_I
I=001A
3

7) Battery quantities setting (normally 4 pcs)

BAT_NUM
NUM=000
4

8) Battery type setting

0000: In default, constant charging is 13.8V and floating charging is 13.7V
0001: Constant voltage and floating voltage setting(Range: 12V-17V)

BAT_TYPE
TYPE= 0001
5

9)Battery Overcharge Protection Voltage(range:8V~18V),normally 17V

UBAT_OVER_CHG
U=017 V
6

10)Battery Discharge Protection Voltage(range:8V~18V),normally 10.5V

UBAT_OVER_DISCHG
U=10.5 V
7

11) Communication address setting

SET_COM_ADDR
ADDR= 1
8

4: Operation

4-1: Key instruction

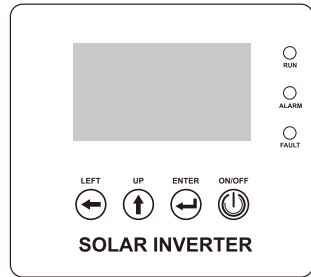

1) ON/OFF: Turn on/off button

◆ Battery power supply status: Turn on the machine and press ON/OFF button for more than 2 seconds until the buzzer beeps and release the button, that is to say, the boot is successful. Shut down: press ON/OFF for more than 2 seconds until the buzzer beeps and then release the button to shut down the machine.

◆ The status of mains supply: under the state of mains supply, the machine can start automatically without pressing the “ON/OFF” key.

◆ The status of PV supply: under the state of PV supply, the machine can start automatically without pressing the “ON/OFF” key.

2) ENTER: Page turning and confirmation key

Press the ENTER key to check the running information after switching on.

3) (UP) & (ENTER): Parameter setting key

Press (UP) and (ENTER) keys at the same time to enter the parameter setting interface. Input the password “103” can switch 8 settings, including constant charging voltage, floating charging voltage, PV charging current, AC charging current, battery number, battery type, battery overcharging voltage and communication address.

For example: if you need to set the constant charging voltage, press UP and ENTER keys at the same time to enter the password interface; Input the password “103” through LEFT key to left shift and UP key, then press ENTER confirmation key to enter parameter setting, and so on. Choose to save after setting the voltage, and press LEFT and ENTER at the same time to exit. Constant charging voltage setting is done.

4) (LEFT)&(UP): Parameter checking key

Press the LEFT and UP keys at the same time to enter parameter checking interface, then you can check the charging voltage, floating voltage, PV charging current, AC charging current, battery quantities, battery type, battery overcharging voltage and communication address. Press LEFT and ENTER button to exit.

4-2: Steps of start up

- 1) Connect loads to the AC output of inverter(Refer to chapter 5 for wiring);
- 2) Connect city power, solar panel and battery, please notice the negative and position side during wiring;
- 3) Close the battery switch, PV switch, mains switch, output switch;
- 4) Press ON/OFF button to start the inverter(start automatically under the state of city power and PV power);
- 5) After 30s when the output voltage is stable, start loads in turn.

4-3: Steps of power off

- 1) Disconnect all loads;
- 2) Turn off the mains switch, PV switch, and output switch;
- 3) Press ON/OFF button to shut down the inverter and disconnect AC output;
- 4) Turn off the battery switch.

5: Working Modes

Main working modes shown as below according to different status and condition. AC/DC switching key(the key is at the back of the machine). If you select AC, the priority mode will be the mains supply ; If you select DC, the priority mode will be battery.

5-1: AC mode

- When mains supply is normal and the PV power is bigger than the load power, the PV power will feed the load completely. It does not consume the energy of the city electricity or the battery. The surplus energy of PV charges the battery.
- When mains supply is normal and the PV power is smaller than the load power, the insufficient part is supplemented by the mains supply; The PV and the mains supply feed the load together.
- When mains supply is abnormal, the machine changes to independent invert mode. When the PV power is bigger than the load power, the PV power will feed the load completely, and the surplus part will charge the battery. When the PV power is smaller than the load power, the insufficient part is supplemented by the battery; the batteries and the PV feed the load together.
- When PV has no generating power, the mains supply will charge and store energy to the battery through the inverter.
- When mains supply is abnormal and there is no PV, batteries will feed the load.

5-2: Battery mode

- When mains supply is normal and PV power is bigger than the load power, PV will feed the load completely. It won't consume mains supply and the battery power, and the surplus PV power will feed the battery.
- When the PV power is smaller than the load power, the insufficient part is supplemented by the battery. The PV and the battery will feed the load together.
- When PV power runs out or very little and the battery is placed to below 48 voltage, the discharge power of the battery will be linearly reduced. The insufficient part will be supplemented by mains supply. And when it reaches the low-voltage protection of the battery, the load will be completely fed by the mains supply .
- When mains supply is abnormal, the machine will work in the independent invert mode. The PV power will feed the load. And if the PV power is insufficient, it is supplemented by the battery.

Note: under the BATT mode, if there is no PV, mains supply won't charge the battery.

6: Wiring

(Remarks: Please refer to the technical parameter table for specific battery voltage and solar panel parameters. This diagram is only for wiring diagram.)

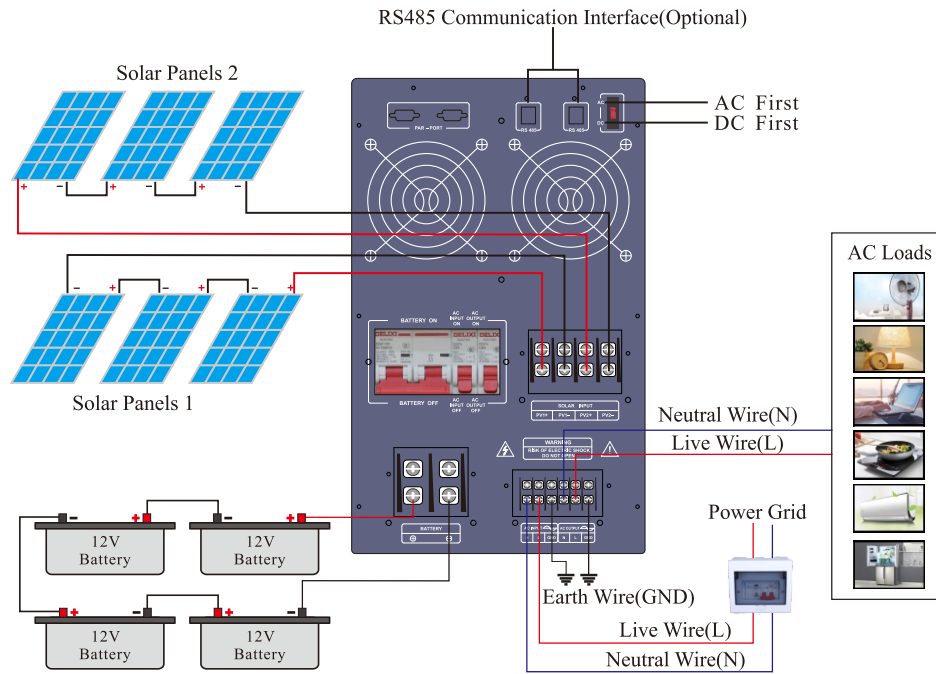

Note:

- Please avoid reverse connection while connecting batteries and solar panels to the inverter;
- If a generator is used as input power, the operation is as follow: start up the generator, after it runs steadily, connect and turn on inverter. When the inverter starts to work, connect user's equipment to the AC output;
- Capacity of generator ≥ 3 times of the rated capacity of inverter.

7. Maintenance

- 1) The inverter just needs the minimum maintenance. And life of Pb(battery) can be preserved by frequent charge.
- 2) Batteries should be charged for every three months if the inverter is long-term unused.
- 3) Lifespan of battery normally lasts for three to five years. It should be replaced in advance if any battery is found in poor state. And the replacement shall be operated by the professional.
- 4) Batteries should be wholly replaced by the instruction of the supplier.
- 5) For every three months, batteries should be discharged (until the inverter shuts down) and recharged. Every charge (by standard inverter) should last at least for 12 hours.
- 6) Among high temperature area, batteries should be discharged and recharged forevery two months. Every charge (by standard inverter) should last at least for 12 hours.

Note:

- Please shut down the inverter and disconnect AC input before replacing batteries.
- Please do not wear metal jewelry such as ring or watch.
- Please use screwdriver with insulated handle and avoid to place tools or metal objects on batteries.
- Please avoid short circuit or reverse connection.

Warning:

- 1) Battery must not be put in the fire, which may cause explosion.
- 2) Shall not open or damage the battery. Electrolyte released will cause harm to eyes and skin and even intoxication.

8: Error and Solution

8-1: Regular Error

Error	Reason	Solution
Unable to boot	Low voltage in battery or overload	Charging the battery or reduce the loads
Shut down with load	Low voltage in battery or overload	Charging the battery or reduce the loads
Alarm for boot	Low voltage in battery or overload	Charging the battery or reduce the loads

8-2: Fault alarm code

Alarm information	Code	Explains	Solutions
NO_ERR	0	No error	The machine runs normally
PV1_Over_Current	1	PV1 over current	Please contact the supplier
Upv1_High	2	PV1 over voltage	Please check the PV voltage whether or not meets machine's requirement
PV1_Temper_High	3	PV1 high temperature	Please check the cooling fan
Upv1_Low	4	PV1 low voltage	Please check whether or not there is sunlight on the solar panels
Ubat_Low_F	5	Battery low voltage	The machine will shut down soon. Please charge the batteries with PV power or mains supply
Ubat_High_F	6	Battery high voltage	Please check the battery voltage whether or not meets the machine's requirement
Ubat_Low_A	7	Battery low voltage	The machine will shut down soon. Please charge the batteries with PV power or mains supply.
Bat_Temper_High	8	Battery high temperature	Please check the batteries' surrounding temperature.
Upv2_Low	9	PV2 low voltage	Please check whether or not there is sunlight on the solar panels
PV2_Over_Current	10	PV2 over current	Please contact the supplier
Upv2_High	11	PV2 high voltage	Please check the voltage of solar panels whether or not meets the machine's requirement
Ugrid_High_SD	12	Grid high voltage	Please check the mains supply whether or not is within the range of the specifications.
PV2_Temper_High	13	PV2 high temperature	Please check the cooling fan
Uinv_High	14	Inverting high voltage	Please contact the supplier
Ugrid_High_Fred	15	Grid high frequency	Please check the mains supply whether or not is within the range of the specifications.
Ugrid_Low_Fred	16	Grid low frequency	Please check the mains supply whether or not is within the range of the specifications.
Ugrid_High_V	17	Grid high voltage	Please check the mains supply whether or not is within the range of the specifications.
Ugrid_Low_Fa	18	Grid low voltage	Please check the mains supply whether or not is within the range of the specifications.
INV_Over_Current	19	Inverting over current	Please check whether or not the user's equipment is short-circuited or the current is too high
INV_Temper_High	20	Inverting high temperature	Please check the cooling fan
INV_Temper_Err	21	Inverting temperature sensor disconnects	Please contact the supplier
PV1_Temper_Err	22	PV1 temperature sensor disconnects	Please contact the supplier
PV2_Temper_Err	23	PV2 temperature sensor disconnects	Please contact the supplier
Iload_Over_C	24	Load over current	Please check whether or not the user's equipment is short-circuited or the current is too high
Itz_Over	25	Over current protection	Please check whether or not the user's equipment is short-circuited or the current is too high. And please cut off the power and restart

REV_Charge	26	Reverse charge protection	Please contact the supplier
REV_Transf	27	Reverse transformer polarity	Please contact the supplier
ISO_Island	28	Island protection	Please check whether or not the mains supply was cut off
SW_Stop	29	Shut down	Please check whether or not the mains supply was cut off
Communication_Err	30	Communication error	Please contact the supplier
Ugrid_Low_C	31	Grid low voltage	Please check the mains supply whether or not is within the range of the specifications.
INV_Overload	32	Inverting overload	Please check whether or not overload
Ubat_High_alarm	33	Battery high voltage	Please check the mains supply whether or not is within the range of the specifications.
Ugrid_Low_SD	34	Grid low voltage	Please check the mains supply whether or not is within the range of the specifications.
Iload_Over_load	35	Load overload	Please check whether or not the user's equipment is short-circuited or the current is too high
REV1_Charge	36	Reverse charge protection	Please contact the supplier

9. Appendix--485 Communication Port

Definition of pin :

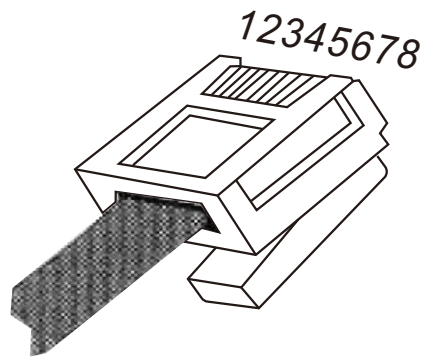
PIN1-----RS485-A	
PIN2-----RS485-B	
PIN3-----NC	
PIN4-----GND	
PIN5-----NC	
PIN6-----NC	
PIN7-----NC	
PIN8-----NC	

NC: refer to as not connect.

10: Technical Specification

Model: ZRG		30248
PV Input	Max input voltage(Voc) (At the lowest ambient temperature)	150V
	MPPT tracking range	60V~120V
	Recommended operating voltage range	60V~80V
	MPPT route number	2
	Max input power	1960W/1960W
Battery (Flexible configuration)	Type of battery	Lead-acid battery / Lithium-ion battery(Need to customize)
	Rated voltage	48V
	Max charging current (Can be set,Recommended 0.1C)	70A(PV)/ 35A(Mains)
	Float voltage(Can be set)	55.2V
	Charge voltage(can be set)	56.8V
AC Input	Rated voltage	220V/230V
	Input voltage range	187V~264V
	Rated input frequency	50Hz/60Hz±5Hz
	Loss protection time	≤2S
	Reconnection time	30S
AC Output (PV/Battery mode)	Rated output power	3KW
	Rated output voltage	220V/230V
	Output voltage accuracy	±2%
	Rated output frequency	50Hz/60Hz
	Output frequency accuracy	±1%
AC Output (Mains mode)	Rated output power	3KW
	Output voltage	187V~264V
	Output frequency	47~52Hz/57~62Hz
Regular Parameter	Topology	Transformer isolation
	Display	LCD+LED
	Communication(Optional)	RS485/APP(WIFI monitoring or GPRS monitoring)
	Operating temperature	-10℃~60℃ (Derating above 45℃)
	Storage temperature	-20℃~60℃
	Noise	≤60dB
	Relative humidity	20%~95%(No condensation)
	Highest altitude	2000m(Derating above 2000m)
	Machine dimension (L*W*Hmm)	467*280*508
	Package dimension (L*W*Hmm)	530*340*635
	N.W.(Kg)	40
	G.W.(Kg)	47
Installation Method	Tower	

Note: All specification is subject to change without prior notice.

Warranty Card

Customer Name: _____ Tel.: _____

Address: _____

Brand: _____ Model: _____

Serial No.: _____ Date of Purchase: _____

Bought From: _____

Invoice Number: _____ Invoice Price: _____

Warranty instruction

- Please keep this warranty card as proof of maintenance.
- The warranty period is 1 year from the date of purchase.
- During the warranty period, under the condition of normal use and maintenance, if damage caused by the product's own quality, the company will provide free repair and replacement parts after verification.
- The company reserves the right to maintain and interpret all contents.

Free maintain won't be given under the following circumstance:

- The damage caused by the manipulation that hasn't follow the requests of the manual.
- The product has been repaired, modified by technicians other than our company's, and any internal parts of the product have been replaced by users.
- The product number has been altered or product is inconsistent with the warranty card.
- Damage caused by careless use, penetration of water or other substances into the product.
- Damage caused by accident or natural disaster.

Certificate

Name: _____

Model: _____

Inspectors: _____

Date: _____

Products have been tested qualified by standard and permitted to deliver.